



**THE
FAST
AND THE
FURIOUS™**

SUPERBIKES

OPERATOR'S MANUAL

- Failure to properly operate this machine could result in malfunction or accident, so please read this manual carefully before commencing operation. Be sure to operate the machine as described in this manual.
- Keep this manual available and ready for use when necessary.
- If the machine fails to function correctly, immediately turn off the machine and contact your local distributor. (60 Day Warranty, from date of purchase)

Table of contents

Safety

Warnings, Cautions & Notices.....4-5

Setup & Operation

Product Specifications6
 Inspection & Installation.....7
 Seat assembly & Power Up8
 Networking.....9-10

Diagnostics, Audits & Adjustments

Diagnostic Menu System 11
 Menu Navigation 11
 Main Menu 11

Diagnostics & Tests Menu

Switch Test..... 12
 Dipswitch Test..... 13
 Sound Test..... 13
 Monitor Test 14
 Lamp Test 14
 L.E.D. Test 15
 Coin Meter Test..... 15
 Watchdog Tests Menu 16

Game Audits Menu

General 1 Audits Menu 17
 General 2 Audits Menu 17
 Course Audits 18
 Course Wins Audit 18
 Placings Audit 18
 Vehicles Audit 19
 Riders Audit..... 20
 Upgrades Audit 20
 Tunes Audit..... 21
 Stunts Audit..... 21

Adjustments Menu

Price Menu 22
 Money Unit Menu 23
 Coin Value Menu..... 23
 Coin Per Bill Pulse Menu 24
 Coin Per Credit Menu..... 24
 Credit To Start Menu..... 25
 Free Play Menu..... 26

(Chapter 3. Diagnostics Audits & Adjustments continued)

Credit To Continue Menu.....26
 1st Place Free Race Menu26
 Multi-Play Free Race Menu27
 Start Time Bonus Menu27
 Checkpoint Time Bonus Menu28
 Attract Audio Menu28
 Game Difficulty Menu29
 Max Credits Menu.....29
 Max Game Length Menu30
 Auto Pilot Menu31
 High Score Reset Menu31

Utilities Menu

CRC Check Menu32
 Clear Credit Menu32
 Clear Audit Menu.....33
 Clear High Scores Menu33
 Clear Player Stats Menu34
 Default Adjustments Menu34
 Factory Restore Menu.....35
 Calibration Menu35
 Volume Menu..... 36
 Attract Volume Menu36

Maintenance, Wiring & Troubleshooting

Troubleshooting Guide.....37
 Hard Drive Recovery.....38
 BIOS Power Management Setting....39
 Monitor Adjustments.....40
 Cabinet Wiring.....41-42
 Troubleshooting Notes

Parts, Exploded Assembly Diagrams Copyright Information

For Parts or Service contact your local Distributor or:

**Betson Enterprises
303 Paterson Plank Road
Carlstadt, New Jersey**



**Main Phone: (201) 438-1300
Toll Free Phone: (800) 524-2343
Part Phone: (800) 828-2048**

CAUTION:

- The specifications of this product are subject to change without notice for reasons such as performance.
- The content of this game, its main devices and design are protected under each federal law concerning patent, copyright and other intellectual properties.
- Unauthorized reproduction of this document or any of its contents is strictly forbidden.

Safety Instructions

Safety instructions apply to operators and service personnel. Read these instructions before preparing the video game machine for play. Other safety instructions appear throughout this manual.

WARNING: TRANSPORTING THE VIDEO GAME MACHINE (VGM).

The VGM contains glass and fragile electronic devices. Use appropriate care when transporting. Avoid rough handling when moving the VGM.

WARNING: DISCONNECT POWER.

Always turn the power OFF and unplug the VGM before attempting service or adjustments unless otherwise instructed. Installing or repairing components with the power switched ON can damage the components and void warranty.

WARNING: GROUND GAMES.

Avoid electrical shock! Do not plug in the VGM until you have inspected and properly grounded it. Only plug into a grounded, three-wire outlet. Do not use a "cheater" plug, or cut off the ground pin on the line cord.

WARNING: AVOID ELECTRICAL SHOCKS.

This VGM does not utilize an isolation transformer. Internal cabinet AC is not isolated from the external AC line.

WARNING: HANDLE FLOURESCENT TUBE AND CRT WITH CARE.

If you drop a fluorescent tube or CRT and it breaks, it will implode! Shattered glass can fly eight feet or more from the implosion.

WARNING: CHECK POWER SELECTOR, LAMP.

Set the 115/230 VAC selector switch on the power supply for the correct line voltage on the installation site. Verify that the fluorescent lamps are rated for the proper line voltage.

WARNING: USE PROPER FUSE.

Avoid electrical shock! Replacement fuses must be identically rated to the original fuse!

WARNING: ATTACH CONNECTORS PROPERLY.

Be sure all connectors mate properly. If connectors do not slip in easily, do not force them. Connectors are often keyed and only connect one way. Check for correct orientation.

WARNING: USE EXTREME CARE WHEN HANDLING PC.

The PC contains sensitive components such as a hard drive. Do not handle roughly. Call your distributor before servicing PC internal components. Ask about warranty information as it relates to the PC.

WARNING: HAZARD TO EPILEPTICS.

A very small portion of the population has a condition, which may cause them to experience epileptic seizures or have momentary loss of consciousness when viewing certain kinds of flashing lights or patterns that are present in our daily environment. These persons may experience seizures while watching some kinds of television pictures or playing certain video games. Peoples who have not had any previous seizures may nonetheless have an undetected epileptic condition.

If you or anyone in your family has experienced symptoms linked to an epileptic condition (e.g., seizures or loss of awareness), immediately consult your physician before using any video games.

We recommend that parents observe their children while they play video games. If you or your child experience the following symptoms: dizziness, altered vision, eye or muscle twitching, involuntary movements, loss of awareness, disorientation, or convulsions, DISCONTINUE USE IMMEDIATELY and consult your physician.



Setup and Operation

Product Specifications:

OPERATING REQUIREMENTS

ELECTRICAL POWER

Domestic 120VAC @ 60 Hz, 5 amps
Foreign 240VAC @ 50Hz, 2.5 amps

TEMPERATURE

32° F to 100°F
(0°C to 38°C)

HUMIDITY

Not to exceed 95% relative humidity.

27-INCH SITDOWN MODEL MAIN CABINET SHIPPING DIMENSIONS

Height = 87 inches (220.98 cm)
Depth = 48 inches (80.01cm)
Width = 36 inches (91.44cm)

27-INCH SITDOWN MODEL MAIN CABINET SHIPPING WEIGHT

Weight = 495 lbs. (224.53 Kg)

27-INCH SEAT SHIPPING DIMENSIONS

Height = 54 inches (137.16 cm)
Depth = 75 inches (190.5 cm)
Width = 39 inches (99.06 cm)

27-INCH MODEL SEAT SHIPPING WEIGHT

Weight = 125 lbs. (57.04Kg)

INSPECTION AND INSTALLATION

WARNING: Use extreme care when moving or servicing the game cabinet. Don't plug in the game until you have read this manual.

Please check the following after the game after the game has been removed from its shipping crate and placed in a suitable play or service area.

Make sure that the game cabinet is level. Adjust the casters as needed.

1. Check the AC line cord for any visible signs of damage to the plug or line cord insulation.
2. Check for possible shipping damage to the following:
 - Player interfaces: seat, handlebars, buttons, keypad and brake and shift levers.
 - Seat assembly.
 - Monitor glass.
 - Cabinet backdoor.
 - Cabinet coin door.
 - Cabinet and seat decals.
3. Remove the coin door key from the coin return chute.
4. Open the top coin door and locate the key for the backdoor and the cashbox.
5. Locate hardware kit. Included are: tamper proof tool kit, crossover network cable, line cord and seat hardware fasteners (8 sets)
6. Remove the backdoor the backdoor from the cabinet and visually inspect the electronic components.
7. Verify that all connectors are secure and that the bottom of the cabinet is free of loose objects, which may have possibly come loose during shipping.

Seat Assembly Procedure

WARNING: The cabinet is top heavy. Install only on level surface. Use the leg levelers to make sure the cabinet and seat are stable. Do not push against plastic parts during movement. Raise the shipping screws all the way up before game can be played.

1. Roll the cabinet and seat to the intended installation location. Make sure setup up area is suitable for your game operation. Allow for at least 3 – 4 feet of clearance from the bike for player and public traffic convenience and safety during game play. Allow for enough clearance from the backdoor for proper airflow. Do not block the air intake or exhaust vents located in the back of the game.

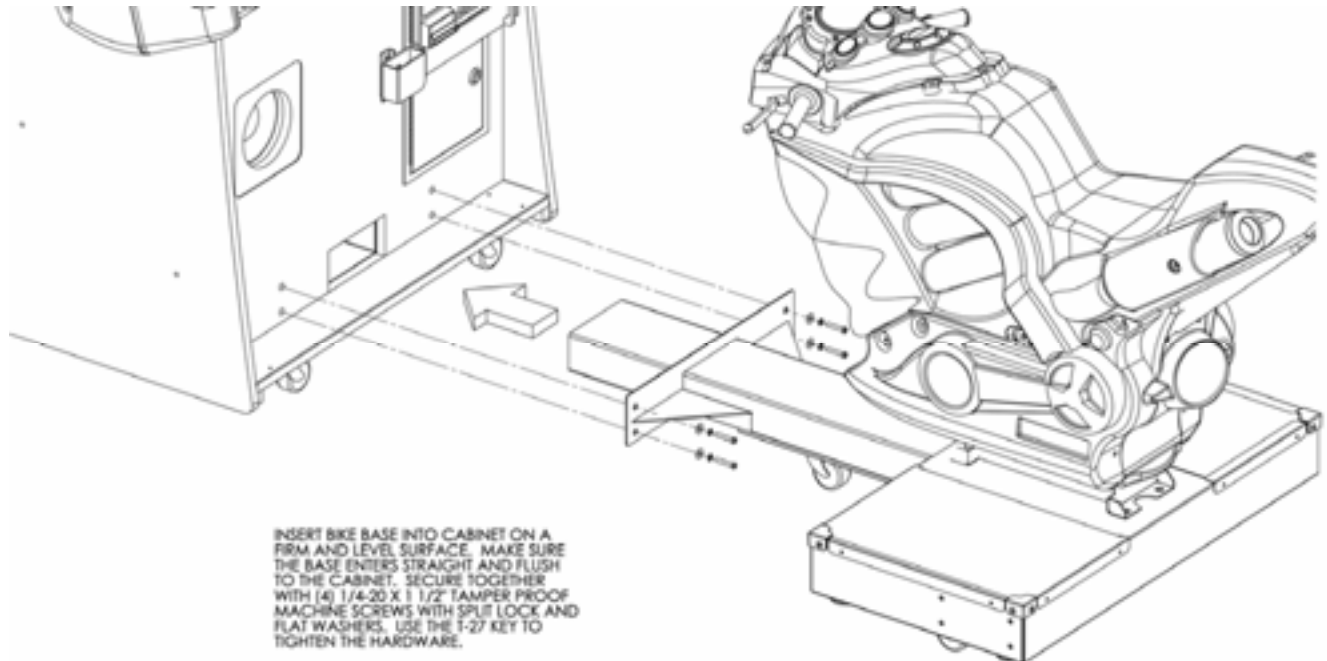

2. Position the seat base assembly so that it is aligned with the mounting holes in the lower main cabinet housing the monitor. Push the seat assembly forward to meet the mounting holes and find the four 1/4 -20 x 2" bolts and large flat washers provided in the hardware bag inside the cashbox. Make all necessary cable connections and ensure no wires are pinched during the attachment process.
3. Adjust all levelers until both cabinet and seat are flush and parallel with each other.
4. Tighten the screws firmly using a T-27 Torx tool.
5. Raise the shipping screws located under the bike assembly. One is located on each underside of the bike. This keeps the bike stable during transport or service. Raise both shipping screws all the way up without removing it completely out. This ensures safe keeping for future use.

Power Up Procedure

1. Plug the game line cord into an appropriately wired and fused AC receptacle.
2. Locate the game AC main switch to the bottom left side on back of the game cabinet.
3. Turn the switch to the ON position.
4. The game attract feature will begin after the game is finished loading- approximately 1 minute.
5. Proceed to Switch Test of this document and verify proper game operation.

Game Networking

NOTICE: To link the two games together, use the crossover cable provided in the spare parts bag. Use of another cable other than the one shipped with the game could void warranty or cause games not to link. Use network cables, which are at least CAT5 grade.

Networking Considerations

Each FNFSB game ships with a cross over cable for linking 2 games. Optionally, a hub and network patch cords can be installed to link 3 or more games.

Take care to protect exposed game wiring from general foot traffic around the game. Use a conduit or wire way to protect the cables as needed.

Please mark linking cables for your game if other such cables are in the vicinity to avoid confusion. Network cables are not marked or coded.

Avoid routing the network cables near sources of heat, moisture or electrical energy such as neon lights, compressor motors, transformers etc.

Networking Setup 2 Games

1. Remove the cross over network cable from the parts bag located inside the cashbox.
2. If you are linking two games connect each end of the cable to the network jack behind each PC.

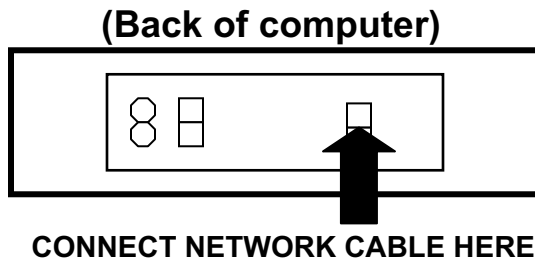

3. Neatly route the cable through the notch on the back of the cabinet.
4. Use the Dipswitch diagram below for enabling link feature and master/slave configuration. The Dipswitch is located on the JAMMA I/O board. The JAMMA I/O board is mounted inside the back of the cabinet.
5. Reset all games simultaneously and verify that link is successful. If not, check the Dipswitch settings and make sure that the network cable is connected properly and secured. Please refer to the troubleshooting guide in this manual for more details.

DIP SWITCH DIAGRAM:

DIP SW#	SW1	SW2	SW3	SW4	SW5	SW6	SW7	SW8
Player1 / MASTER	OFF	OFF	OFF				*	ON
Player 2	ON	OFF	OFF				*	ON

Networking Setup 3 - 8 Games

1. Prepare network hub with enough ports and correct number of patch cables to support the number of games that you plan to link. Network hub and cables are not shipped with the games and are sold separately.
2. Connect each end of the cable to the network jack behind each PC.
3. Connect each of the opposite ends of the cables to the network hub. Please refer to the network hub manual for other networking considerations specific to your hub.

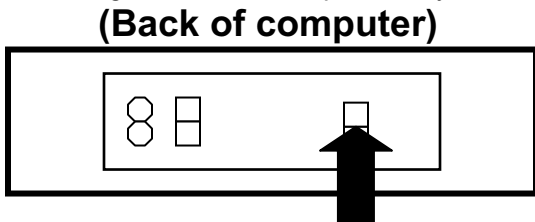

CONNECT NETWORK CABLE HERE

1. Neatly route the cable through the notch on the back of the cabinet.
2. Use the DIPswitch diagram below for enabling link feature and master/slave configuration. The DIPswitch is located on the JAMMA I/O board. The JAMMA I/O board is mounted inside the back of the cabinet.
3. Reset both games simultaneously and verify that link is successful. If not, check the DIPswitch settings and make sure that the network cable is connected properly and secured. Please refer to the Game Troubleshooting Guide on this manual for more details.
4. Reset all games simultaneously and verify that link is successful. If not, check the Dipswitch settings and make sure that the network cable is connected properly and secured. Please refer to the troubleshooting guide in this manual for more details.

DIP SWITCH DIAGRAM:

DIP SW#	SW1	SW2	SW3	SW4	SW5	SW6	SW7	SW8
Player1 / MASTER	OFF	OFF	OFF					ON
Player 2	ON	OFF	OFF					ON
Player 3	OFF	ON	OFF					ON
Player 4	ON	ON	OFF					ON
Player 5	OFF	OFF	ON					ON
Player 6	ON	OFF	ON					ON
Player 7	OFF	ON	ON					ON
Player 8	ON	ON	ON					ON

Adjustments, Audits & Diagnostics

Locate the *Service Button Panel*. It is mounted inside the coin door area on top of the cash box vault. Press the **TEST** button to access the **Test Menu**.

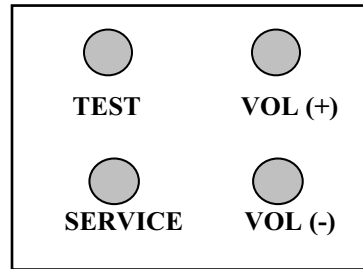

Menu Navigation:

Button	Action
Test	Enter Operator Screen
Start Button	Enter/Select Item Sub-Menu
Vol. (+) or View Button	Scroll up thru Menu items
Vol. (-) or Tunes Button	Scroll down thru Menu items
Service or Shift Lever	Exit to previous Menu

MAIN MENU

The **Test Main Menu** appears when the **TEST** button is pressed.

<p>Test Main Menu</p> <ul style="list-style-type: none"> Diagnostics Game Audits Adjustments Utilities Calibration Volume Attract mode volume Exit 	<p>Version Information</p> <ul style="list-style-type: none"> Version OS Version Exe Version Date Time Machine I.D. Jusb vers. Release 4
<p>Press Volume +/- or View/Tunes to Select. Press Test or Start to Activate Press Service or use Shift Lever to Exit.</p>	

Diagnostics Menu System

From the **Main Menu**, select **Diagnostics** and enter to view options.

<p>Diagnostics Menu</p> <p><u>Switch Test</u> DIP Switch Test Sound Test Wheel Test Monitor Test Lamp Test LED Test Coin Meter Test Watchdog Test Exit</p>	<p>Diagnostics</p>
<p>Press Volume +/- or View/Tunes to Select. Press Test or Start to Activate Press Service or use Shift lever to Exit</p>	

Switch Test

From the **Diagnostics** select and enter **Switch Test**. Verify proper switch input function using this menu. Each switch activated will be indicated on the test screen in corresponding yellow box and will be accompanied by a switch active sound indicator. Verify pot value for min, center and max are correct. If not, proceed to Calibration section of this manual. Press and hold the **Service Button** for three seconds to return to the **Diagnostics Menu**.

SWITCH TEST																				
<table border="1" style="width: 100%; border-collapse: collapse;"> <tr> <th style="text-align: left;"><u>Lean/Throttle/ Info</u></th> <th style="text-align: left;">Input Device</th> <th style="text-align: left;">Pot Value</th> <th style="text-align: left;">Min</th> <th style="text-align: left;">Center</th> <th style="text-align: left;">Max</th> </tr> <tr> <td></td> <td>Lean</td> <td><input style="width: 100px;" type="text"/></td> <td></td> <td></td> <td></td> </tr> <tr> <td></td> <td>Throttle</td> <td><input style="width: 100px;" type="text"/></td> <td></td> <td></td> <td></td> </tr> </table>			<u>Lean/Throttle/ Info</u>	Input Device	Pot Value	Min	Center	Max		Lean	<input style="width: 100px;" type="text"/>					Throttle	<input style="width: 100px;" type="text"/>			
<u>Lean/Throttle/ Info</u>	Input Device	Pot Value	Min	Center	Max															
	Lean	<input style="width: 100px;" type="text"/>																		
	Throttle	<input style="width: 100px;" type="text"/>																		
<p><u>Button Info</u></p> <p>View Start Tunes Shift Handbrake Coin 1 Coin 2 Bill Acceptor</p>	<p><u>TVVS Info</u></p> <p>Service credit Volume up (+) Volume Down (+) Test</p>	<p><u>Keypad Info</u></p> <table style="width: 100%; border-collapse: collapse;"> <tr> <td style="text-align: center;">1</td> <td style="text-align: center;">2</td> <td style="text-align: center;">3</td> </tr> <tr> <td style="text-align: center;">4</td> <td style="text-align: center;">5</td> <td style="text-align: center;">6</td> </tr> <tr> <td style="text-align: center;">7</td> <td style="text-align: center;">8</td> <td style="text-align: center;">9</td> </tr> <tr> <td style="text-align: center;">*</td> <td style="text-align: center;">0</td> <td style="text-align: center;">#</td> </tr> </table>	1	2	3	4	5	6	7	8	9	*	0	#						
1	2	3																		
4	5	6																		
7	8	9																		
*	0	#																		
<p>Hold Service or Start to Exit</p>																				

DIP Switch Test

From the **Diagnostics Menu** select and enter **DIP Switch Test**. Verify correct DIPswitch settings. Please refer to Appendix n. Press the Tunes Button to return to **Diagnostics Menu**.

DIP SWITCH VALUES		
VALUE STATE	SWITCH	
ON	8	- NET ENABLED
ON	7	- JAPANESE ENABLED
ON	6	
ON	5	
ON	4	
ON	3	-
ON	2	- MACHINE ID 1-8
ON	1	-

Sound Test

From the **Diagnostics Menu** select and enter **Sound Test**. Verify that marquee, cabinet and seat sound volume and quality are good. Press the Tunes Button to return to **Diagnostics Menu**

<p>Sound Test Menu</p> <p>Change Music Change Effect</p> <p>Play 100Hz Test Play 1000Hz Test</p> <p>Set Pan Center Set Pan Left Set Pan Right</p> <p>Exit</p>	<p>Sound Test</p> <p>Current Music Track:</p> <p>Current Sound Effect:</p>	<p>Note: Use Pan functions to test left/right speakers separately.</p> <p>Use 100-1Khz test to verify subwoofer sound quality.</p> <p>Go to Volume section to adjust sound level.</p>
<p>Press Volume +/- or View/Tunes to Select. Press Test or Start to Activate Press Service or use Shift lever to Exit</p>		

Monitor Test

From the **Audio/Video Options** menu, select and enter **Color Bars & Purity**. Verify correct color and purity for Red, Blue and Green screens. Use the convergence screen to also verify linearity. See Appendix n.

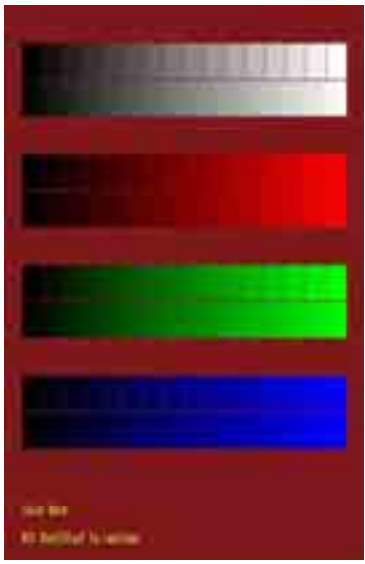
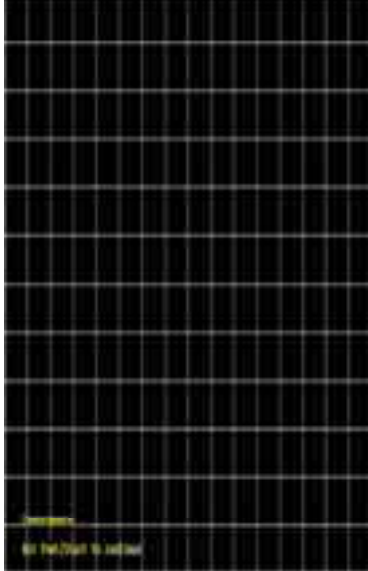
	<ul style="list-style-type: none"> • White Screen • Red Screen • Green Screen • Blue Screen 	
<p>Color Bar</p>	<p>Purity Screen</p>	<p>Convergence</p>

Lamp Test

From the **Diagnostics Menu** select and enter **Lamp Test**. Use View1 or View 3 to select the lamp and press Start to activate that lamp. Verify that ALL lamps are working.

<p>Lamp Test Menu</p> <p>ALL Lamps ON ALL Lamps OFF View Lamp ON Start Lamp ON Tunes Lamp ON Exit</p>	<p>Lamp Test</p>	<p>Note:</p> <p>Lamp function could also be verified using Switch Test.</p> <p>Please check the coin door lamps as part of your game diagnostic check.</p>
<p>Press Volume +/- or View/Tunes to Select. Press Test or Start to Activate Press Service or use Shift lever to Exit</p>		

L.E.D. Test

From the ***Diagnostics Menu*** select and enter ***L.E.D. Test***. Advance the meter once using by pressing Start. Press the Tunes Button to return to ***Diagnostics Menu***. Verify that all LED's are working.

LED Test Menu

All LED's On
All LED's Off
Speedo Cycle
Brake Cycle
Tail pipe Cycle

Exit

LED Test

Press Volume +/- or View/Tunes to Select. Press Test or Start to Activate
Press Service or use Shift lever to Exit

Coin Meter Test

From the ***Diagnostics Menu*** select and enter ***Coin Meter Test***. Advance the meter once using by pressing Start. Press the Tunes Button to return to ***Diagnostics Menu***.

Hit Test/Start to advance coin meter.

Press Service or Tunes to Exit

Watchdog Test

From the ***Diagnostics Menu*** select and enter ***Watchdog Test***. The game will reset in approximately 6 seconds. The watchdog feature allows the PC to monitor normal game software and hardware operation.



Game Audits

From the ***Main Menu***, select ***Game Audits*** and enter to view options.

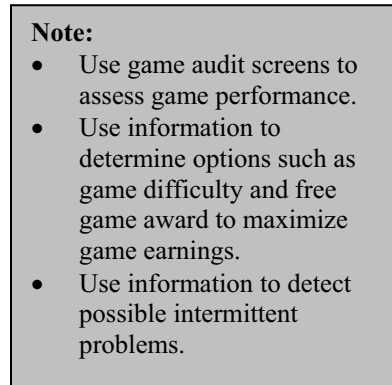
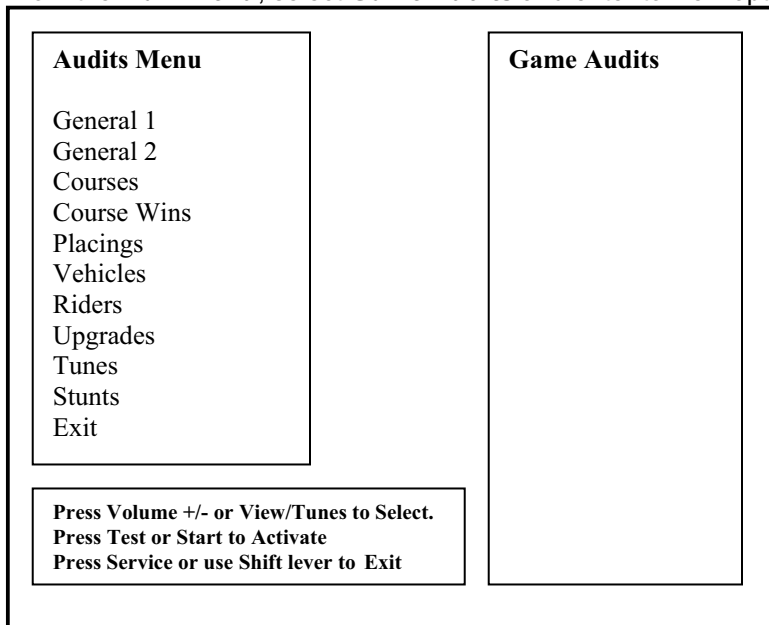

General 1 Audits

From the ***Audits Menu***, select ***General 1*** and enter to view general game statistics. Press the Tunes Button to return to ***Main Menu***.

<p>Audits Menu</p> <p><u>General 1</u> General 2 Courses Course Wins Placings Vehicles Upgrades Tunes Stunts</p> <p>Exit</p>	<p>General Audits</p> <p>Time Game On Time Game Played Average Time per Game</p> <p>Games Played Games Started Game Continued Game Timed Out Free Games PIN Games Link Games</p> <p>Boot Ups Test Mode Entries Unfinished Games</p>
<p>Press Volume +/- or View/Tunes to Select. Press Test or Start to Activate Press Service or use Shift lever to Exit</p>	

General 2 Audits

From the ***Audits Menu***, select ***General 2*** and enter to view additional general game statistics. Press the Tunes Button to return to ***Main Menu***.

<p>Audits Menu</p> <p>General 1 <u>General 2</u> Courses Course Wins Placings Vehicles Upgrades Tunes Stunts</p> <p>Exit</p>	<p>General Audits</p> <p>Auto Games Manual Games</p> <p>Low Cam Time Med Cam Time High Cam Time</p> <p>Coindrops Coindrops Slot 0 Left Coindrops Slot 1 Right Coindrops Slot 2 DBV</p> <p>Current Credits Current Coins</p>
<p>Press Volume +/- or View/Tunes to Select. Press Test or Start to Activate Press Service or use Shift lever to Exit</p>	

Course Audits

From the ***Audits Menu***, select ***Courses*** and enter to view individual information on each course. View how many times each course is selected, as well as its popularity by overall percentage. Press the Tunes Button to return to ***Main Menu***.

<p>Audits Menu</p> <p>General 1 General 2 <u>Courses</u> Course Wins Placings Vehicles Upgrades Tunes Stunts</p> <p>Exit</p>	<p>Course Selects/Percentage</p> <p>Switzerland Hawaii Shanghai Florida Baja Chicago Detroit Sturgis Monaco</p>
<p>Press Volume +/- or View/Tunes to Select. Press Test or Start to Activate Press Service or use Shift lever to Exit</p>	

Course Wins Audit

From the ***Audits Menu***, select ***Courses Wins*** and enter to view individual win and overall percentage information on each course. Press the Tunes Button to return to ***Main Menu***.

<p>Audits Menu</p> <p>General 1 General 2 Courses <u>Course Wins</u> Placings Vehicles Riders Upgrades Tunes Stunts</p> <p>Exit</p>	<p>Course Wins/Percentage</p> <p>Switzerland Hawaii Shanghai Florida Baja Chicago Detroit Sturgis Monaco</p>
<p>Press Volume +/- or View/Tunes to Select. Press Test or Start to Activate Press Service or use Shift lever to Exit</p>	

Placings Audit

From the ***Audits Menu***, select ***Placing*** and enter to view individual count for each standing and percentage information. Use this information to determine game difficulty adjustments to properly reward players and maximize game earning performance. Press the Tunes Button to return to ***Main Menu***.

<p>Audits Menu</p> <p>General 1 General 2 Courses Course Wins <u>Placings</u> Vehicles Riders Upgrades Tunes Stunts</p> <p>Exit</p>	<p>Placings/Percentage</p> <p>1st Place 2nd Place 3rd Place 4th Place 5th Place 6th Place 7th Place 8th Place</p> <p>Avg. Place:</p> <p>Max. Winning Streak: Max. Lose Streak: Current Win Streak: Current Lose Streak:</p>
<p>Press Volume +/- or View/Tunes to Select. Press Test or Start to Activate Press Service or use Shift lever to Exit</p>	

Vehicles Audit

From the ***Audits Menu***, select ***Vehicles*** and enter to view individual count for each vehicle selection and percentage information. Press the Tunes Button to return to ***Main Menu***.

<p>Audits Menu</p> <p>General 1 General 2 Courses Course Wins Placings <u>Vehicles</u> Riders Upgrades Tunes Stunts</p> <p>Exit</p>	<p>Vehicle Selects/Percentage</p> <p>MONSTER S4R YZF R-1 RSV 1000 NINJA ZX-10R VULCAN 800 DRIFTER MGS-01 CORSA YZF R-6 PAUL SMART 1000 L.E. KX-250 WARRIOR VMAX SS1000 DS SXV</p>
<p>Press Volume +/- or View/Tunes to Select. Press Test or Start to Activate Press Service or use Shift lever to Exit</p>	

Riders Audit

From the ***Audits Menu***, select ***Riders*** and enter to view individual count for each rider selected and percentage information. Press the Tunes Button to return to ***Main Menu***.

Audits Menu General 1 General 2 Courses Course Wins Placings Vehicles <u>Riders</u> Upgrades Tunes Stunts Exit	Rider Selects/Percentage Studbiker Youngblood Bulletproof Motobiker Biker Jaylo Blonde
Press Volume +/- or View/Tunes to Select. Press Test or Start to Activate Press Service or use Shift lever to Exit	

Upgrade Audit

From the ***Audits Menu***, select ***Upgrade Audit*** and enter to individual count for each vehicle feature upgrade selection and percentage information. Press the Tunes Button to return to ***Main Menu***.

Audits Menu General 1 General 2 Courses Course Wins Placings Vehicles <u>Upgrades</u> Tunes Stunts Exit	Upgrades/Percentage Decal Tires Nitro Neon Body Engine Upgrade Users:
Press Volume +/- or View/Tunes to Select. Press Test or Start to Activate Press Service or use Shift lever to Exit	

Tunes Audit

From the ***Audits Menu***, select ***Tunes*** and enter to view individual count for each tune selected and playtime information. Use Shift lever or press Service to Exit to main menu.

<p>Audits Menu</p> <p>General 1 General 2 Courses Course Wins Placings Vehicles Upgrades <u>Tunes</u> Stunts</p> <p>Exit</p>	<p>Tunes (Time in Each)</p> <p>Deep 1 Deep 2 Deep 3 Deep 4 Deep 5 Deep 6 Deep 7 Deep 8 Deep 9</p>
<p>Press Volume +/- or View/Tunes to Select. Press Test or Start to Activate Press Service or use Shift lever to Exit</p>	

Stunts Audit

From the ***Audits Menu***, select ***Stunts*** and enter to view individual count for each stunt performed. Use Shift lever or press Service to Exit to return to ***Main Menu***

<p>Audits Menu</p> <p>General 1 General 2 Courses Course Wins Placings Vehicles Upgrades Tunes <u>Stunts</u></p> <p>Exit</p>	<p>Stunts</p> <p>Endos Slides Back flips Front flips Helis (helicopter spins) Rolls Wipeouts Nitros Autopilot triggers</p>
<p>Press Volume +/- or View/Tunes to Select. Press Test or Start to Activate Press Service or use Shift lever to Exit</p>	

Adjustment Menu

From the **Main Menu**, select **Adjustment Menu** and enter. The Adjustment Menu allows you to customize the game. Each variable will change an aspect of the game play and appearance. Optimizing these settings should result in continued high player interest and game earnings. You can monitor the affects of these options by comparing audit information before and after the changes have been implemented. Press Start to Select. Use Shift lever or press Service to Exit.

<p>Adjustments Menu</p> <ul style="list-style-type: none"> Pricing Freeplay 1st Place-Free Race Multi-play win free race Start Time Bonus Checkpoint Time Bonus Game Difficulty Speed Measurements Attract Audio Max Credits Multiplay Win Gets Free Game Max Name Length Plays For High Score Reset Auto Pilot Available Exit 	<p>Preference And Adjustments</p>
<p>Press Volume +/- or View/Tunes to Select. Press Test or Start to Activate Press Service or use Shift lever to Exit.</p>	

Price Menu

From the **Adjustment Menu**, select **Pricing** and enter. The Pricing Menu allows you to customize the pricing options and currency acceptor credit settings. Please note that if the acceptor is not present, the price setting will not have an effect on the game. Press Start to Select. Use Shift lever or press Service to Exit.

<p>Pricing Menu</p> <ul style="list-style-type: none"> Money Unit Coin Value Coins Per Bill Pulse Coins Per Credit Credits to Start Credits to Continue Exit 	<p>Credit Options</p>
<p>Press Volume +/- or View/Tunes to Select. Press Test or Start to Activate Press Service or use Shift lever to Exit</p>	

Money Unit Menu

From the **Pricing Menu**, select **Money Unit** and enter. Select the currency, which applies to the games location, and press Start to select. Press Start to Select. Use Shift lever or press Service to Exit.

<p>Select Currency</p> <p>USD US Dollars AUD AUS Dollars CAD CAN Dollars EUR Euros GBP British Pounds DEM Deutschmarks FRF French Franks JPY Japanese Yen ITL Italian Lire CHF Swiss Franks BRL Brazilian Reals DKK Danish Kroner MXN Mexican Pesos RUR Russian Rubles KRW Korean Won CNY Chinese Won</p> <p>Cancel</p>	<p>Credit Options</p>
<p>Press Volume +/- or View/Tunes to Select. Press Test or Start to Activate Press Service or use Shift lever to Exit</p>	

Coin Value Menu

From the **Pricing Menu**, select **Coin Value** and enter. Choose the coin value based on the currency selected and the coin acceptor type or setting. Press Start to Select. Use Shift lever or press Service to Exit.

<p>Coin Value</p> <p>0.01 USD 0.05 USD 0.10 USD 0.25 USD 0.50 USD 1.00 USD 2.00 USD 5.00 USD 10.00 USD 20.00 USD 50.00 USD 100.00 USD Exit</p>	<p>Credit Options</p>
<p>Press Volume +/- or View/Tunes to Select. Press Test or Start to Activate Press Service or use Shift lever to Exit</p>	

Coin Per Bill Pulse Menu

From the **Pricing Menu**, select **Coin per Bill Pulse Menu** and enter. Choose the equivalent coin value based on the bill acceptor currency type or settings. Press Start to Select. Use Shift lever or press Service to Exit.

Coin Per Bill Pulse? 1 2 3 4 5 10 20 25 50 100 Exit	Credit Options
Press Volume +/- or View/Tunes to Select. Press Test or Start to Activate Press Service or use Shift lever to Exit	

Coin Per Credit Menu

From the **Pricing Menu**, select **Coin per Credit Menu** and enter. Choose the number of coins required to earn one credit. One credit equals to one purchased game. Press Start to Select. Use Shift lever or press Service to Exit.

Coin Per Credit 1 2 3 4 5 6 7 8 9 10 Cancel	Credit Options
Press Volume +/- or View/Tunes to Select. Press Test or Start to Activate Press Service or use Shift lever to Exit	

Credit To Start Menu

From the **Pricing Menu**, select **Credit To Start Menu** and enter. Choose the number of credits required to start one game. Press Start to Select. Use Shift lever or press Service to Exit.

<p>Credits to Start</p> <p>1 2 3 4 5 6 7 8 9 10</p> <p>Cancel</p>	<p>Credit Options</p>
<p>Press Volume +/- or View/Tunes to Select. Press Test or Start to Activate Press Service or use Shift lever to Exit</p>	

Coin Per Credit To Continue Menu

From the **Pricing Menu**, select **Credit To Continue Menu** and enter. Choose the number of credits required to continue from the current game. Press Start to Select. Use Shift lever or press Service to Exit.

<p>Credits to Continue</p> <p>1 2 3 4 5 6 7 8 9 10</p> <p>Cancel</p>	<p>Credit Options</p>
<p>Press Volume +/- or View/Tunes to Select. Press Test or Start to Activate Press Service or use Shift lever to Exit</p>	

Free Play Menu

From the **Adjustment Menu**, select **Free Play** and enter. Select whether the game should be in Free Play Mode. In this mode, simply pressing the Start button can start a game. Press Start to Select. Use Shift lever or press Service to Exit.

<p>Free Play Activate?</p> <p>Yes No</p> <p>Cancel</p>	<p>Preference and Adjustments</p>
<p>Press Volume +/- or View/Tunes to Select. Press Test or Start to Activate Press Service or use Shift lever to Exit</p>	

1st Place Free Race Menu

From the **Adjustment Menu**, select **1st Place Free Race** and enter. The player wins a free race for a 1st place overall finish during a single of networked race game. Press Start to Select. Use Shift lever or press Service to Exit.

<p>First Place Wins Free Race?</p> <p>Yes No</p> <p>Cancel</p>	<p>Preference and Adjustments</p>
<p>Press Volume +/- or View/Tunes to Select. Press Test or Start to Activate Press Service or use Shift lever to Exit</p>	

Multi-play wins free race

From the **Adjustment Menu**, select **Multiplay Win Gets Free Race** and enter. Winner of a networked game wins a free race if active. Default setting is No. Press Start to Select. Use Shift lever or press Service to Exit.

<p>Multiplay 1st wins free race?</p> <p>Yes No</p> <p>Cancel</p>	<p>Preference and Adjustments</p>
<p>Press Volume +/- or View/Tunes to Select. Press Test or Start to Activate Press Service or use Shift lever to Exit.</p>	

Start Time Bonus

From the **Adjustment Menu**, select **Start Time Bonus** and enter. Select the amount of time in seconds given to the player to reach the first checkpoint. Press Start to Select. Use Shift lever or press Service to Exit.

<p>Start Time?</p> <p>30 seconds 40 seconds 50 seconds 60 seconds 70 seconds 80 seconds 90 seconds 100 seconds 110 seconds 120 seconds</p>	<p>Preference and Adjustments</p>
<p>Press Volume +/- or View/Tunes to Select. Press Test or Start to Activate Press Service or use Shift lever to Exit</p>	

Checkpoint Time Bonus

From the **Adjustment Menu**, select **Checkpoint Time Bonus** and enter. Select the amount of time in seconds given to the player to reach the next checkpoint after the first checkpoint is reached. Press Start to select. Use Shift lever or press Service to Exit

<p>Turn On Attract Mode Audio?</p> <p>Yes No</p> <p>Cancel</p>	<p>Preference and Adjustments</p>
<p>Press Volume +/- or View/Tunes to Select. Press Test or Start to Activate Press Service or use Shift lever to Exit</p>	

Attract Audio menu

From the Adjustment menu, select **Attract Audio** and enter. Select whether audio is active while in attract mode. Press start to select. Use Shift lever or press Service to Exit.

<p>Turn on Attract Mode audio?</p> <p>Yes No</p> <p>Cancel</p>	<p>Preferences and adjustments</p>
<p>Press Volume +/- or View/Tunes to Select. Press Test or Start to Activate Press Service or use Shift lever to Exit</p>	

Game Difficulty Menu

From the *Adjustment Menu*, select *Game Difficulty* and enter. The default difficulty level is 5. Press Start to Select. Use Shift lever or press Service to Exit.

From the *Adjustment Menu*, select *Speed Measurement* and enter. Select which unit is to be used to measure car speed. Choose MPH or Miles per Hour. Choose KPH or Kilometers per Hour. Press Start to Select. Use Shift lever or press Service to Exit.

<p>Game Difficulty Level?</p> <p>1 Easier 2 3 4 5 6 7 8 9 10 Harder Cancel</p>	<p>Preference and Adjustments</p>
<p>Press Volume +/- or View/Tunes to Select. Press Test or Start to Activate Press Service or use Shift lever to Exit</p>	

Note:

Please reference the game Audit information to determine the appropriate difficulty setting for your location. Compare changes in game statistics and game revenue before and after the change.

Max Credits Menu

From the *Adjustment Menu*, select *Max Credits* and enter. Press Start to Select. Press Tunes or Service to Exit.

<p>Max Number Of Credits?</p> <p>10 15 20 25 30 35 40 45 50</p> <p>Cancel</p>	<p>Preference and Adjustments</p>
<p>Press Volume +/- or View/Tunes to Select. Press Test or Start to Activate Press Service or use Shift lever to Exit.</p>	

Max Name Length Menu

From the ***Adjustment Menu***, select ***Max Name Length*** and enter. This refers to the number of allowable characters when entering player names. Press Start to Select. Use Shift lever or press Service to Exit.

<p>Maximum Name length?</p> <p>3 4 5 6 7</p> <p>Cancel</p>	<p>Preference and Adjustments</p>
<p>Press Volume +/- or View/Tunes to Select. Press Test or Start to Activate Press Service or use Shift lever to Exit.</p>	

Auto Pilot Menu

From the ***Adjustment Menu***, select ***Auto Pilot Available*** and enter. Press Start to Select. Use Shift lever or press Service to Exit.

<p>Auto pilot available?</p> <p>Yes No</p> <p>Cancel</p>	<p>Preference and Adjustments</p>
<p>Press Volume +/- or View/Tunes to Select. Press Test or Start to Activate Press Service or use Shift lever to Exit</p>	

High Score Reset Menu

From the **Adjustment Menu**, select **Plays for High Score Reset** and enter. Select the number of plays before high score table is reset. Press Start to Select. Use Shift lever or press Service to Exit.

<p>Plays For High Score Reset?</p> <p>1000 2000 2500 5000 7500 10000 12500 15000 17500 20000</p> <p>Cancel</p>	<p>Preference and Adjustments</p>
<p>Press Volume +/- or View/Tunes to Select. Press Test or Start to Activate Press Service or use Shift lever to Exit</p>	

Utilities Menu

From the **Test Main Menu**, select **Utilities** and enter. The Utilities Menu contains tools, which the operator can use to manage game adjustments or reset key game and player score and statistic information. The option to perform a game factory restore can also be accessed.

<p>Utilities Menu</p> <p>CRC Check</p> <p>Clear Credits Clear Audits Reset High Scores Reset Player Stats Default Adjustments Factory Restore</p> <p>Cancel</p>	<p>Utilities</p> <p>Please note the following:</p> <p>Setting default adjustments or performing a factory restore will require calibration afterwards.</p> <p>A factory restore will perform all the resets listed at the left, clearing credits, audits, high scores, and player data.</p>
<p>Press Volume +/- or View/Tunes to Select. Press Test or Start to Activate Press Service or use Shift lever to Exit</p>	

Note:

- Information will be permanently erased by Clear or Reset functions.
- It is often ideal to perform a factory restore when the game is being moved to a new location.
- Record your game audit information if performing any of the above functions.

CRC Check Menu

From the ***Utilities Menu***, select ***CRC Check*** and enter. Performing CRC check verifies the integrity of the software. Press Start to Select. Use Shift lever or press Service to Exit.

<p>Really Perform CRC Check?</p> <p>Yes No</p> <p>Cancel</p>	<p>Utilities</p> <p>Please note the following:</p> <p>Setting default adjustments or performing a factory restore will require calibration afterwards.</p> <p>A factory restore will perform all the resets listed at the left, clearing credits, audits, high scores, and player data.</p>
<p>Press Volume +/- or View/Tunes to Select. Press Test or Start to Activate Press Service or Shift to Exit</p>	

Clear Credit Menu

From the ***Utilities Menu***, select ***Clear Credits*** and enter. Performing Clear Credit will delete any remaining credits posted. Press Start to Select. Use Shift lever or press Service to Exit.

<p>Really Clear Credits?</p> <p>Yes No</p> <p>Cancel</p>	<p>Utilities</p> <p>Please note the following:</p> <p>Setting default adjustments or performing a factory restore will require calibration afterwards.</p> <p>A factory restore will perform all the resets listed at the left, clearing credits, audits, high scores, and player data.</p>
<p>Press Volume +/- or View/Tunes to Select. Press Test or Start to Activate Press Service or Shift to Exit</p>	

Clear Audit Menu

From the **Utilities Menu**, select **Clear Audit** and enter. Performing Clear Audit will delete all audit information found on the Audit Menu. Please record them if you ever need to reference the information. Press Start to Select. Use Shift lever or press Service to Exit.

<p>Really Clear Credits?</p> <p>Yes No</p> <p>Cancel</p>	<p>Utilities</p> <p>Please note the following:</p> <p>Setting default adjustments or performing a factory restore will require calibration afterwards.</p> <p>A factory restore will perform all the resets listed at the left, clearing credits, audits, high scores, and player data.</p>
<p>Press Volume +/- or View/Tunes to Select. Press Test or Start to Activate Press Service or Shift to Exit</p>	

Clear High Scores Menu

From the **Utilities Menu**, select **Clear High Scores** and enter. Performing Clear High Score will clear the all high score tables. Press Start to Select. Use Shift lever or press Service to Exit.

<p>Really Clear High Scores?</p> <p>Yes No</p> <p>Cancel</p>	<p>Utilities</p> <p>Please note the following:</p> <p>Setting default adjustments or performing a factory restore will require calibration afterwards.</p> <p>A factory restore will perform all the resets listed at the left, clearing credits, audits, high scores, and player data.</p>
<p>Press Volume +/- or View/Tunes to Select. Press Test or Start to Activate Press Service or Shift to Exit</p>	

Clear Player Stats Menu

From the **Utilities Menu**, select **Clear Player Stats** and enter. Performing Clear Player Stats will clear all player information, including PIN, car upgrades and money earned. Press Start to Select. Use Shift lever or press Service to Exit.

<p>Really Clear Player Stats?</p> <p>Yes No</p> <p>Cancel</p>	<p>Utilities</p> <p>Please note the following:</p> <p>Setting default adjustments or performing a factory restore will require calibration afterwards.</p> <p>A factory restore will perform all the resets listed at the left, clearing credits, audits, high scores, and player data.</p>
<p>Press Volume +/- or View/Tunes to Select. Press Test or Start to Activate Press Service or Shift to Exit</p>	

Default Adjustments Menu

From the **Utilities Menu**, select **Default Adjustment** and enter. Performing Default Adjustment setting will restore game adjustments back to its manufacturer recommended settings. The game will need to be re-calibrated. Press Start to Select. Use Shift lever or press Service to Exit.

<p>Really Set Default Adjustments?</p> <p>Yes No</p> <p>Cancel</p>	<p>Utilities</p> <p>Please note the following:</p> <p>Setting default adjustments or performing a factory restore will require calibration afterwards.</p> <p>A factory restore will perform all the resets listed at the left, clearing credits, audits, high scores, and player data.</p>
<p>Press Volume +/- or View/Tunes to Select. Press Test or Start to Activate Press Service or Shift to Exit</p>	

Factory Restore Menu

From the **Utilities Menu**, select **Factory Restore** and enter. Performing Factory Restore will restore game adjustments back to its manufacturer recommended settings and clear all audit information. The game will need to be re-calibrated. Press Start to Select. Use Shift lever or press Service to Exit.

<p>Really Perform Factory Restore?</p> <p>Yes No</p> <p>Cancel</p>	<p>Utilities</p> <p>Please note the following:</p> <p>Setting default adjustments or performing a factory restore will require calibration afterwards.</p> <p>A factory restore will perform all the resets listed at the left, clearing credits, audits, high scores, and player data.</p>
<p>Press Volume +/- or View/Tunes to Select. Press Test or Start to Activate Press Service or Shift to Exit</p>	

Calibration Menu

From the **Test Main Menu**, select **Calibration** and enter. Making sure that the seat and Throttle are properly calibrated is the easiest way to make sure that your motorcycle game can maximize its earning potential. Follow the screen instructions carefully. Verify proper calibration on the Switch Test screen. Check and make sure that the minimum, center and maximum values correspond to the actual position of the control.

<p>Calibration</p>	
<input type="checkbox"/>	<p>Lean seat to center; then hit Test/Start</p>
<input type="checkbox"/>	<p>Lean seat left; then hit Test/Start</p>
<input type="checkbox"/>	<p>Lean seat right; then hit Test/Start</p>
<input type="checkbox"/>	<p>Roll Throttle and release; Then Hit Test/Start</p>
<input type="checkbox"/>	<p>Roll Throttle and release; Then Hit Test/Start</p>
<input type="checkbox"/>	<p>Hit Test/Start to Exit</p>

Note:

- If the game requires constant re-calibration, check the controls for mechanical wear or damage. Replace if necessary.
- Normal wear and tear of the controls means that calibration should be part of the games scheduled maintenance.

Volume Menu

From the **Test Main Menu**, select **Volume** and enter. This refers to the game volume while in play. Use the Volume Up/ Volume Down button on the service panel to adjust volume level. Press Start to Select. Use Shift lever or press Service to Exit.

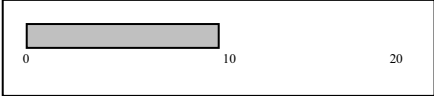
<p>Volume</p> 	<p>Volume Adjust</p> <p>Volume: 10/20</p> <p>Current Track: DNB</p>
<p>Press Volume +/- or View/Tunes to Select. Press Test or Start to Activate Press Service or Shift to Exit</p>	

Note:

- Adjusting the volume while in attract mode only affects the attract volume and the not the actual game volume.
- Adjustment to game volume must be done while on Volume Adjust screen or while on game mode.
- Adjust volume levels relative to location and environment.

Attract Volume Menu

From the **Test Main Menu**, select **Attract Volume** and enter. This refers to the attract mode volume. Use the Volume Up/ Volume Down button on the service panel to adjust volume level. Press Start to Select. Use Shift lever or press Service to Exit.

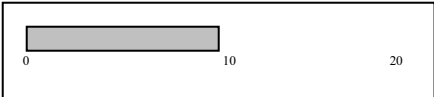
<p>Attract Volume</p> 	<p>Attract Volume Adjust</p> <p>Volume: 10/20</p> <p>Current Track: DNB</p>
<p>Press Volume UP/DOWN to Adjust Press Test Button to Accept Press Service Button to Exit</p>	

TROUBLESHOOTING GUIDE

PROBLEM	POSSIBLE CAUSE	SOLUTION
Game will not power up	Game not plugged in.	Plug game into receptacle.
	Game not turned on.	Turn ON main power switch
	Game fuse is blown	Check game fuse.
	No power to receptacle.	Plug game into powered receptacle.
	PC power switch is OFF	Turn PC power switch ON.
	PC BIOS set wrong.	See Appendix B.
“No Signal” Message	Video cables not secure.	Check and secure video connector.
	PC not turned ON.	Turn ON power to PC.
No video display.	No power to video display.	Check power to video display.
		see <i>Game will not power up.</i>
No sound.	Audio cable not connected.	Check audio cable connection.
	Speaker not connected.	Check speaker connection.
“I/O Board Missing”	USB connector not connected.	Check USB connector from PC to I/O board. Perform Hard Drive Recovery
	Bad game power supply	Check for proper connection and voltage to i/o board. Replace cabinet power supply.
Game will not load.	New Hard Drive installed.	Power cycle by un-plugging game. Perform Hard Drive Recovery
	Hard Drive data corrupted.	Perform Hard Drive Recovery.
Game Freezes	Secure Dongle Loose	Secure and Tighten Dongle
	Poor Ventilation	Check Fan Operation and Airflow
	USB cable loose	Remove and Reinsert USB both ends of cable
	Failing or Bad Power Supply	Check Power Supply Output or Replace With Known Good.
	Corrupted Hard Drive	Perform CRC Check. Re-Image if bad.
Game resets.	Low DC voltage.	Check for proper voltage(+5V,+12V)
	Door lamp is wrong rating.	Use only 5volt lamps.
	Cabinet/PC temperature is too high.	Check that vents and fans are functioning and not obstructed.
	Hard Drive data corrupted.	Perform Hard Drive Recovery..
Not Linking	DIP Switch Set Wrong	Refer to Networking Setup Section.
	Network Cable Bad	Check Connection or Replace
	Game Operator Settings Not The Same.	Make Sure All Settings Are The Same Between Linked Games
Bike Controls Not Working	Bike not securely mated to monitor cabinet.	Secure bike to monitor cabinet using all 4 screws.
	Bike is not level with monitor cabinet	Move game to level surface or adjust leg leveler height as needed.
	Steering potentiometer Is loose	Secure connector firmly into potentiometer.
	Bad or Loose switch	Open fairing to access switches. Verify that switch and connections are good.
LEDs not responding (Speedometer, Brake, Tailpipes LEDs)	Possible bad I/O board	Swap or replace I/O board
	DB9 connectors on PC not secure.	Check DB9 connection and see items under “Bike Controls Not Working” of the Troubleshooting Section(above)
		Swap or replace speedometer board.
		Power Cycle Game.

Warning: Do not connect or disconnect any cables or connectors on this game with the power on. This could potentially damage the game.

Hard Drive Recovery

NOTICE: Fast and the Furious is shipped with a recovery compact disk. Hard drives have been known to occasionally fail for many reasons. Follow the procedure below to restore data on the hard drive if a disk failure should occur. Use extreme care when performing the following procedure and avoid rough handling of pc or CD. Please check the Troubleshooting Guide section of this document. Have the recovery CD ready before you begin.

The following are some symptoms, which may indicate a possible bad hard drive:

- Hard Drive Test reports “bad” or “missing” files. Please refer to Trouble Shooting section of the manual.
- The game fails to finish loading.
- A boot error is reported after game is power cycled or reset.
- The game is looking for a boot CD to be inserted.
- Erratic game or attract mode.

Note: It is important that the USB cable from pc and power is connected to the I/O board before you proceed.

Hard Drive Recovery Procedure:

1. Open the control panel to access the pc.
2. Press the button on the CD drive to open CD tray.
3. Carefully insert the recovery disk into the tray.
4. Press the button on the CD drive to close the CD tray.
5. Turn OFF the pc by pressing the power button once.
6. Turn ON the pc by pressing the power button once.
7. Disk recovery process will begin automatically.
8. A message at the top of the screen will prompt you to remove the disk when process is over. Press the CD drive button to open tray. Remove the recovery disk and store safely.
9. Turn OFF the pc by pressing the power button once.
10. Turn ON the pc by pressing the power button once.

Note: Do not interrupt power or reset the game during the following process!

11. The game will begin to initialize and load. It will typically take about five minutes to complete.
12. The hard drive recovery process is complete when the game enters attract mode.
13. Proceed with control calibration and make necessary game adjustments. Please refer to Setup and Test section of this manual.

-- End of Procedure--

Power Management Setting(BIOS)

NOTE:

Abrupt power cycling of the game should be avoided! Allow 5-10 seconds between turning the game OFF and then ON again.

Fast and Furious Super Bikes is shipped with the correct BIOS settings. Any changes made to the BIOS other than what is described below may adversely affect game functionality.

This BIOS setting allows the PC to automatically power up when AC power is detected. This eliminates the need to manually turn the PC ON after a power disruption.

Procedure:

1. Turn game *OFF*.
2. Connect a PS/2 or USB keyboard to the PC.
3. Hold the DELETE key while turning the PC *ON*.
4. On the **BIOS** menu screen, use the DOWN arrow to scroll down to **Power Management Setup**. Hit ENTER key once.
5. On the **Power Management Setup** menu, use the DOWN arrow to scroll down to **After AC Power Lost**.
6. Use the (+) button to change **After Power Lost** setting to: [**Power ON**].
7. Hit F10.
8. Hit Enter to Save and Exit.
9. PC will reset and begin to load game.

Please note that due to the PC power supply's safety feature which protects against damage due to power disruptions, it may be necessary to remove AC power from the game for a period of 5-10 seconds before the power supply becomes operational again.

Basic Display Adjustments

WARNING: Extremely high voltage is present on the monitor assembly. The monitor does not contain any user serviceable parts. Do not attempt to service the monitor.

The following are display settings, which you should become familiar with. It is important to note that settings may differ slightly between manufacturers and even between displays of the same manufacturers. Certain factors like age of the display could also be a factor. Therefore, the information below should only serve as a reference as actual settings may not be practical in most cases.

Setting	Adjustment
Brightness	Function: Background Brightness or Black Level. Set Level: Black background should appear dark and not gray.
Contrast	Function: Definition/ Sharpness of character against background. Set Level: Outer edges of character or text should not be distorted.
H-Position	Function: Horizontal Position. Side/side centering. Set Level: Picture should be centered from side to side.
H-Size	Function: Horizontal Size. Side/side dimension. Set Level: Picture should be full from side to side.
V-Position	Function: Vertical Position. Up/down centering. Set Level: Picture should be centered up and down.
V-Size	Function: Vertical Size. Up/down dimension. Set Level: Picture should be full from top to bottom.
Pin Cushion	Function: Degree of straightness along both vertical sides of the picture. Set Level: Both sides of the picture should be straight, without curvature.
Degauss	Function: De-magnetizes the picture tube when activated. This eliminates picture discoloration caused by magnetic disturbance around the picture tube.

Digital displays are adjusted using a button type remote adjust board. Below are functional diagrams for Neotec and Wells Gardner 27" digital displays:

Neotec Remote

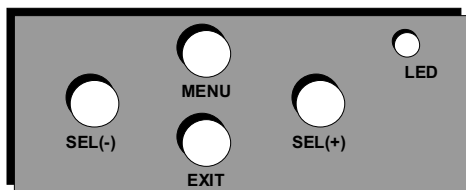

Menu: Open display adjustment menu.
Sel(-): Move down.
Sel(+): Move up.
Exit: Save changes and exit.

Wells-Gardner Remote

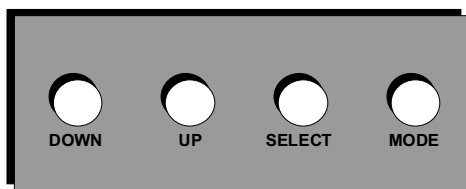

Down: Move down.
Up: Move up.
Select: Choose setting to adjust.
Mode: Exit to adjustment menu.

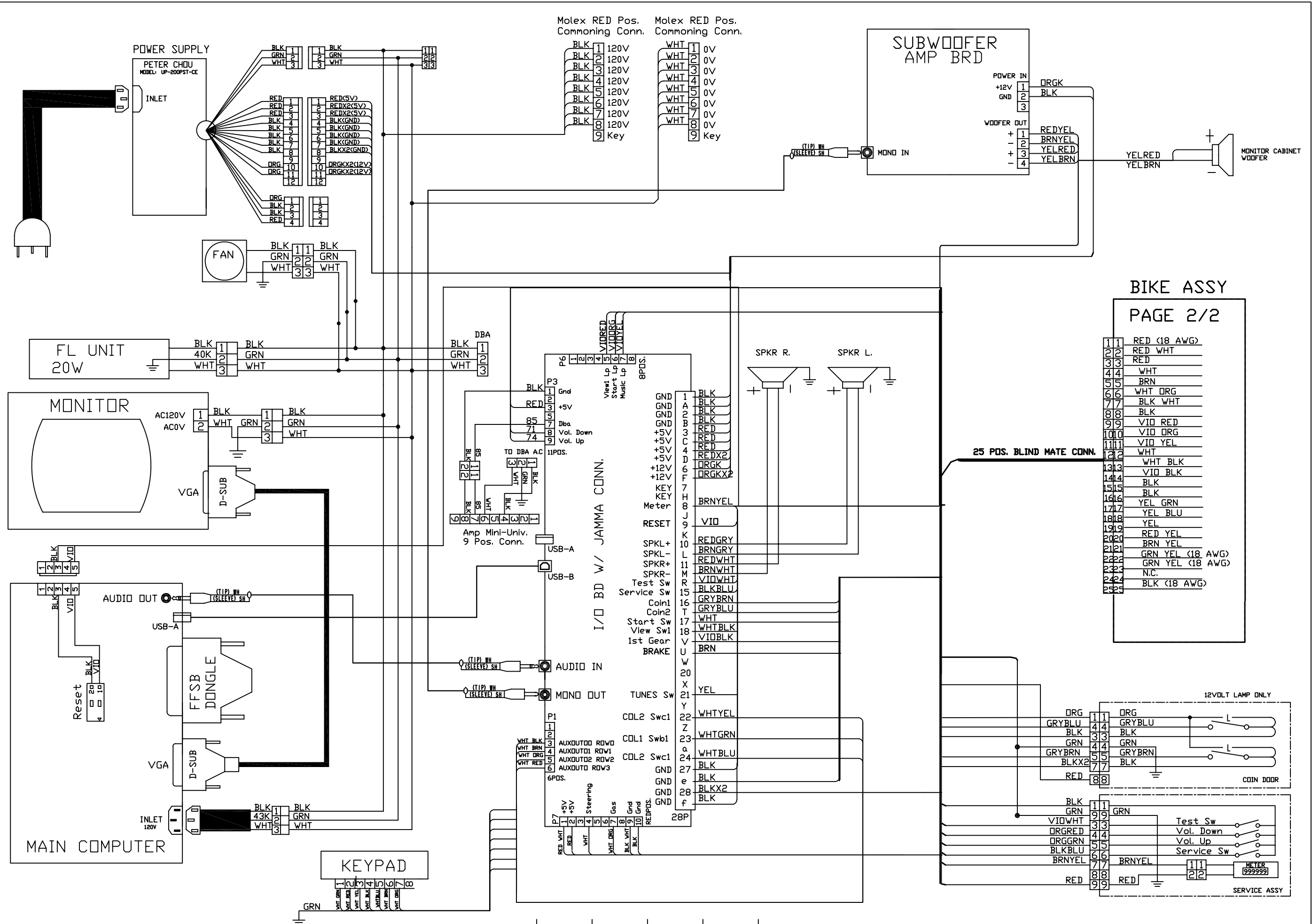

BIKE ASSY
PAGE 2/2

11	RED (18 AWG)
22	RED WHT
33	RED
44	WHT
55	BRN
66	WHT DRG
77	BLK WHT
88	BLK
99	VID RED
1010	VID DRG
1111	VID YEL
1212	WHT
1313	WHT BLK
1414	VID BLK
1515	BLK
1616	BLK
1717	YEL GRN
1818	YEL BLU
1919	YEL
2020	RED YEL
2121	BRN YEL
2222	GRN YEL (18 AWG)
2323	GRN YEL (18 AWG)
2424	N.C.
2525	BLK (18 AWG)

25 PDS. BLIND MATE CONN.

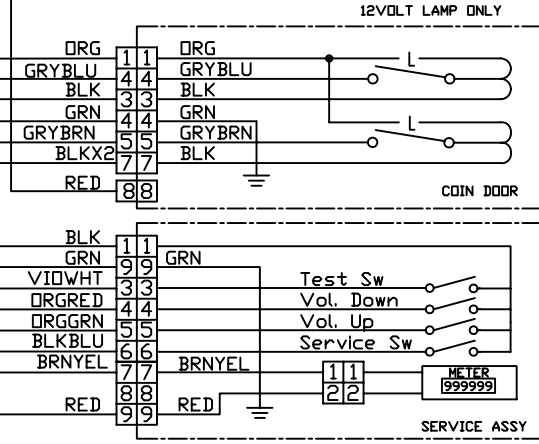

MONITOR CABINET ASSY.

25 POS. BLIND MATE CONN.

1	1	RED (18 AWG)
2	2	RED WHT
3	3	RED
4	4	WHT
5	5	BRN
6	6	WHT DRG
7	7	BLK WHT
8	8	BLK
9	9	VID RED
10	10	VID DRG
11	11	VID YEL
12	12	WHT
13	13	WHT BLK
14	14	VID BLK
15	15	BLK
16	16	BLK
17	17	YEL GRN
18	18	YEL BLU
19	19	YEL
20	20	RED YEL
21	21	BRN YEL
22	22	GRNYEL(18 AWG)
23	23	GRNYEL(18 AWG)
24	24	N.C.
25	25	BLK (18 AWG)

GRNYEL(18 AWG)

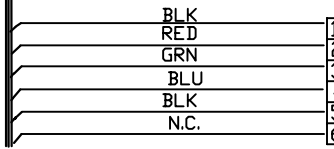
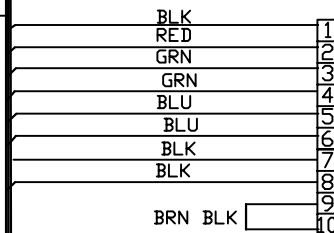
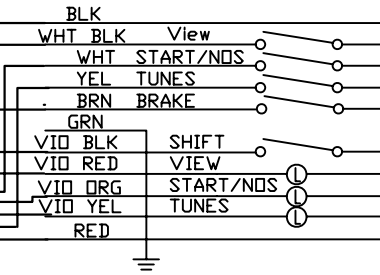
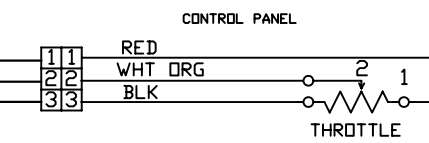
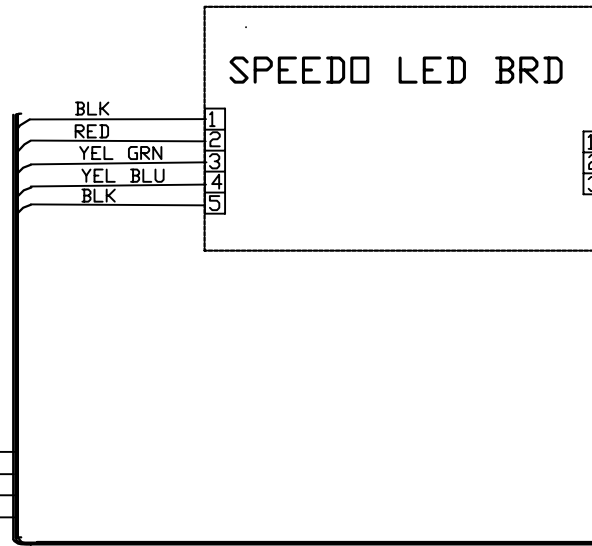
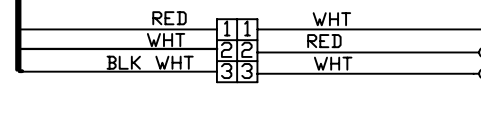
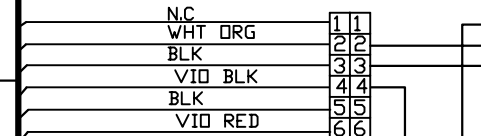
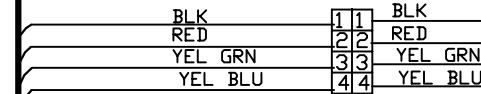
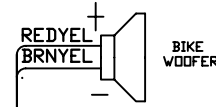

TAIL PIPE LED BRD

TAIL PIPE LED BRD

BRAKE LED BRD

CABINET ASSEMBLED WITH 4" LEG LEVELERS & 2-1/2" CASTERS - INSTALL 1/4" X 3/4" FOAM TAPE AROUND TOP OF LARGER PROFILE (FROM CAB SIDE TO CAB SIDE).

INSTALL WITH 3/4" PHILLIPS WOOD SCREW

INSTALL USING (3) #8 X 3/4" TAMPER PROOF WOOD SCREW WITH WASHER AFTER FRONT BEZEL IS SECURELY MOUNTED

SECURE MONITOR WITH (5) 1/4"-20 X 1" HEX WITH SPLIT LOCK AND FLAT WASHER

INSTALL USING (4) 1/4"-20 X 2" WITH SPLIT LOCK & FLAT WASHER AROUND TUBE FIXTURES SECURE LOWER MOUNTS USING (4) 1/4"-20 X 1" WITH SPLIT LOCK & FLAT WASHER

MARQUEE ART

MOUNT WITH (10) 8-32 X 1" TAMPER PROOF MACHINE SCREW WITH FLAT WASHER

INSTALL (2) 1/4"-20 X 1" WITH SPLIT LOCK AND FLAT WASHER INTO CABINET SIDE FRONT HOLES UTILIZE BEZEL HARDWARE

MOUNT PLATE WITH (6) #8 X 3/4" TAMPER PROOF WOOD SCREW SECURE GREEN GROUND WIRE TO THE BACK OF A KEYPAD PLATE MACHINE SCREW

MOUNT GRILLS WITH (8) #8 X 3/4" WITH FLAT WASHER

INSTALL USING (3) #8 X 3/4" TAMPER PROOF WOOD SCREW WITH WASHER AFTER FRONT BEZEL IS SECURELY MOUNTED

MOUNT BRACKET WITH (2) 8-32 X 1/2" PHILLIPS HEAD

INSTALL USING (4) #8 X 3/4" TAMPER PROOF WOOD SCREW

MOUNT SPEAKER WITH 8-32 NYLOCK HEX NUT

INSTALL USING (4) #8 X 3/4" TAMPER PROOF WOOD SCREW

TOP MOUNTS UTILIZES MONITOR HARDWARE--MOUNT BOTTOM WITH (2) 1/4"-20 X 1" HEX WITH SPLIT LOCK & FLAT WASHER HASP IS OPTIONAL FROM HAPP CONTROLS 30-0200-00

HASP

CONTROLS

NOTE: USE BLACK OXIDE HARDWARE ON ALL VISABLE ASSEMBLY

ITEM NO.	PART NUMBER	DESCRIPTION	QTY.
1	601-0008-01	BIKE MONITOR CABINET	1
2	BikeRackDoorAssy	SUPPLIED WITH CABINET	1
3	600-0015-01plexi	BIKE-MARQUEE PLEXI	1
4	600-0014-01	cabinet full range grill FFSB	2
13	602-0007-00	kick plate FFSB	1
6	600-0012-01	cabinet woofer grill FFSB	1
7	Blind Connect Male	SUPPLIED WITH HARNESS	1
8	Blind Connect Female	SUPPLIED WITH HARNESS	1
9	602-0003-00	INNER TUNNEL SUPPORT	1
10	604-0005-01	bike speaker mounting bracket	1
11	1/4 nut	STANDARD HARDWARE	4
12	4" LEG LEVELER	SUPPLIED WITH CABINET	4
13	ULGuard	SUPPLIED WITH CABINET	1
14	hasp	SPECIAL ORDER--HAPP CONTROLS	1
15	Coaster 2'S	SUPPLIED WITH CABINET	4
16	601-0008-01PCSHLF	SUPPLIED WITH CABINET	1
17	WOOD-MNT-PLATE	SUPPLIED WITH CABINET	1
18	600-0015-01ART	BIKE-MARQUEE ART	1
19	607-0004-00	Speaker 5.25in 4ohm	2
20	P-1-08-00-00-000	FLUORECENT LAMP ASSY 24"-S120x40	1
21	800-0016-01	KEYPAD ASSEMBLY	1
22	800-0015-01	MANIFOLD ASSEMBLY	2
23	809-0002-00	NETEK 27in Flat Monitor	1
24	800-0017-01	FAN ASSEMBLY	1
25	807-0003-00	Speaker 6.5in Woofer Bohm	1
26	800-0006-00	Coin Jcap Assy Mig Width-HAPP 41-300-03	1
27	810-0015-01	test bracket BBHP	1
28	850-0002-01	FFSB PC	1
29	Cabinet Bezel-3 Parts	FRONT AND SIDE BEZELS	1

UNLESS OTHERWISE SPECIFIED		DATE	BY	RAW THRILLS, INC
DESIGNERS ARE IN INCHES	DRAWN			TITLE:
FRACTIONAL	CHECKED			CabinetExplode
PROVIDING A BOM	ENG APPR			
TWO PLACE DECIMALS	MFG APPR			
THREE PLACE DECIMALS				
RESERVED FOR OTHER USE	SA			
REVISIONS	COMMENTS			
REV	DESCRIPTION			
SIZE (DWG. NO.)	REV			
D				
SCALE: 16" WEIGHT:	SHEET 1 OF 1			

PROPRIETARY AND CONFIDENTIAL
THE INFORMATION CONTAINED IN THIS DRAWING IS THE SOLE PROPERTY OF
CREDIT COMMONS AND SHALL NOT BE
DISSEMINATED IN ANY MANNER WITHOUT
THE WRITTEN PERMISSION OF
CREDIT COMMONS AND SHALL BE
PROTECTED.

ITEM NO.	PART NUMBER	DESCRIPTION	QTY.
1	601-00008-01	BIKE, MONITOR CABINET	1
2	BikeBackDoorAssy	DOOR WITH STANDARD LOCK ASSY	1
3	600-00012-01	Cabinet woofer grill FFSB	1
4	Blind Connect Female	SUPPLIED WITH HARNESS	1
5	602-00003-00	INNER TUNNEL SUPPORT	1
6	1/4 nuts	STANDARD HARDWARE	2
7	4"	SUPPLIED WITH CABINET	4
8	Ulguard	SUPPLIED WITH CABINET	1
9	Caster 2"5	SUPPLIED WITH CABINET	4
10	601-00008-01PCSHLF	SUPPLIED WITH CABINET	1
11	WOOD-MNT-PLATE	SUPPLIED WITH CABINET	1
12	B50-00002-01	FFSB PC	1
13	B07-00003-00	Speaker 6.5in Woofer Bohm	1
14	P-1-02-00-00-017	POWER SUPPLY - PETER CHU 200W	1
15	B00-00017-01	FAN ASSEMBLY	1

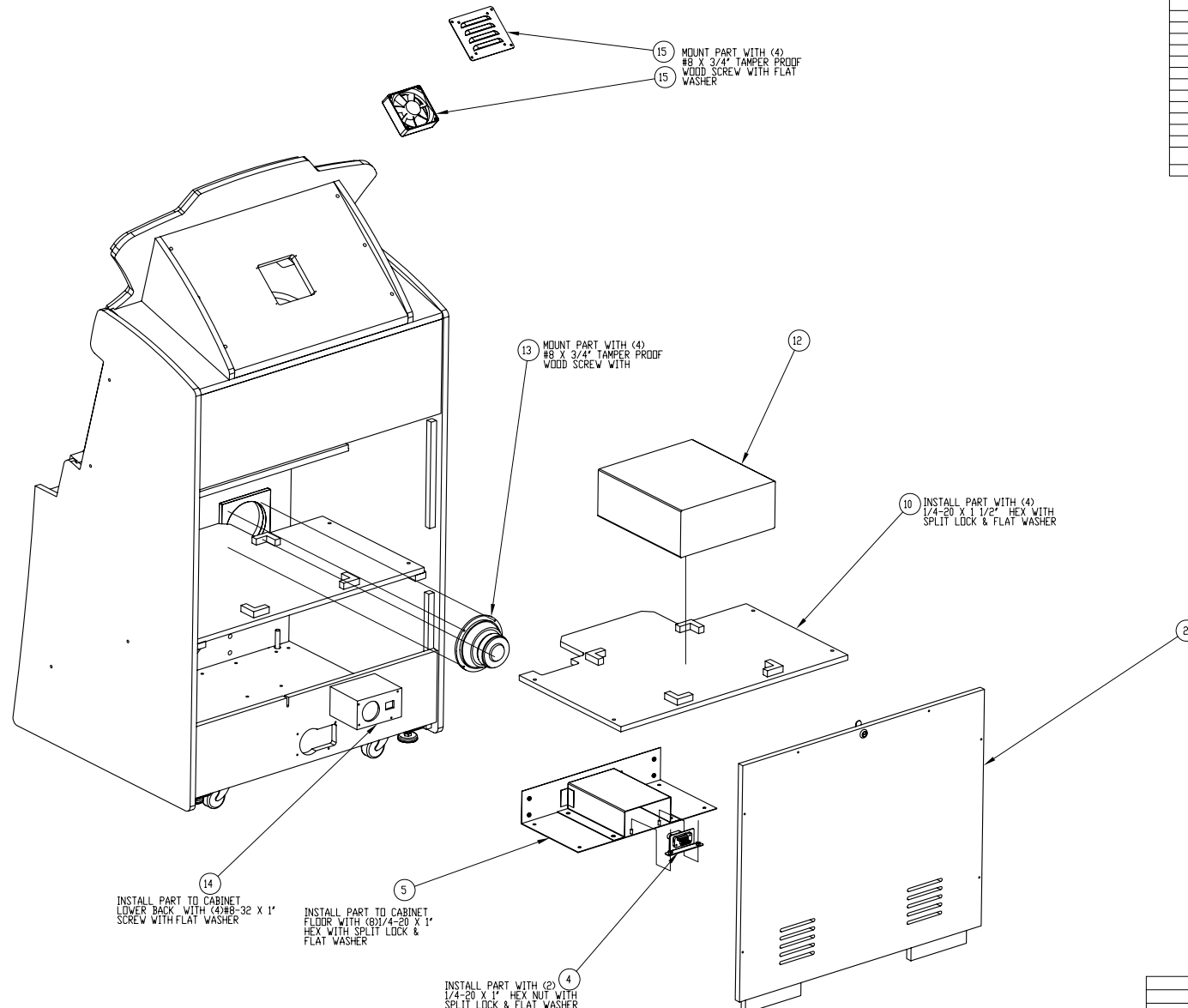

INSTALL PART TO CABINET LOWER BACK WITH (4) #8-32 X 1" SCREW WITH FLAT WASHER

INSTALL PART TO CABINET FLOOR WITH (8) 1/4-20 X 1" HEX WITH SPLIT LOCK & FLAT WASHER

INSTALL PART WITH (2) 1/4-20 X 1" HEX NUT WITH SPLIT LOCK & FLAT WASHER

13 MOUNT PART WITH (4) #8 X 3/4" TAMPER PROOF WOOD SCREW WITH

10 INSTALL PART WITH (4) 1/4-20 X 1 1/2" HEX WITH SPLIT LOCK & FLAT WASHER

15 MOUNT PART WITH (4) #8 X 3/4" TAMPER PROOF WOOD SCREW WITH FLAT WASHER

PROPRIETARY AND CONFIDENTIAL
THE INFORMATION CONTAINED IN THIS DRAWING IS THE SOLE PROPERTY OF ORBITER COMPANY AND SHALL NOT BE REPRODUCED IN ANY MANNER WITHOUT THE WRITTEN PERMISSION OF ORBITER COMPANY AND NEED IS FORWARDED

UNLESS OTHERWISE SPECIFIED		DATE	NAME	RAW THRILLS, INC
DESIGNED BY	BRW			
CHECKED BY				
DATE				
TITLE				CABINET EXPLODE BACK
SCALE				
WEIGHT				
REV				
SHEET 1 OF 1				

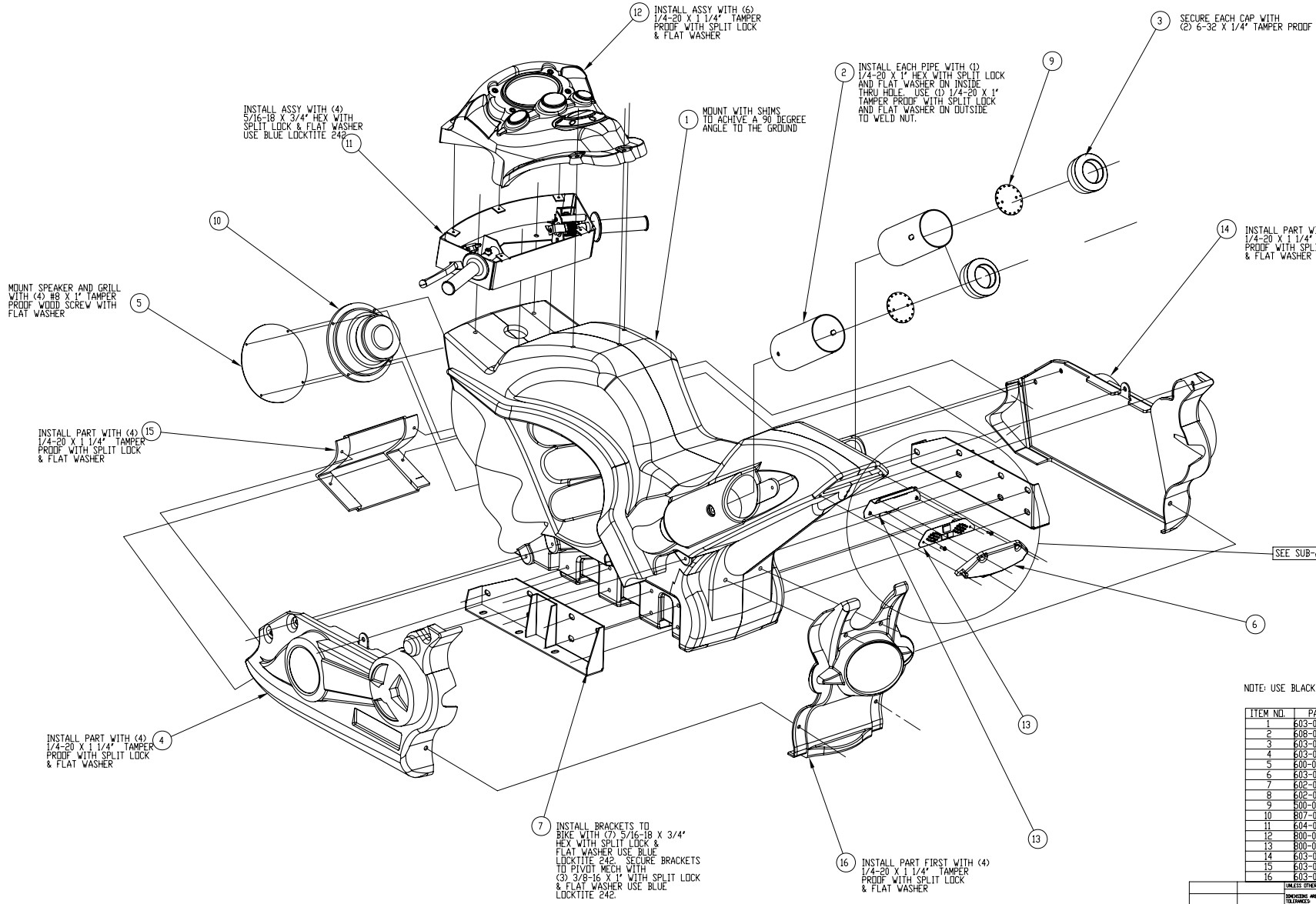

SEE SUB-ASSEMBLY DRAWING

NOTE: USE BLACK OXIDE HARDWARE ON ALL VISIBLE PARTS

ITEM NO.	PART NUMBER	DESCRIPTION	QTY.
1	603-0004-01	Rotonolded Bike - As Built	1
2	608-0005-01	TAILPIPE	2
3	603-0005-01	TAILPIPE CAP	2
4	603-0009-01	BIKE SKIRT LEFT	1
5	600-0003-01	BIKE WOODER GRILL	1
6	603-0006-01	BRACKET LIGHT COVER	1
7	602-0001-00	BRACKET - BIKE MOUNT LEFT	1
8	602-0002-00	BRACKET - BIKE MOUNT RIGHT	1
9	600-0004-01	Tailpipe LED Board	2
10	807-0003-00	Speaker 6.5in Woofer 8ohm	1
11	604-0004-01	Handlebar Assembly-Supertokes	1
12	800-0003-01	Fairing Assembly	1
13	800-0004-01	Tail Light Assembly	1
14	603-0009-01	BIKE SKIRT RIGHT	1
15	603-0001-01	BIKE SKIRT FRONT	1
16	603-0010-01	BIKE SKIRT REAR	1

UNLESS OTHERWISE SPECIFIED	UNIT	DATE	RAW THRILLS, INC
DRAWINGS ARE IN INCHES	MM		
FRACTIONS	DECIMALS		
PROLOG AND 2	ISO #		
THE PLACE OF ORIGIN	REG. APP.		
UNLESS OTHERWISE SPECIFIED	SA		
UNLESS OTHERWISE SPECIFIED	COMMENTS		
NEXT ASSY	USED ON	FABR	
APPLICATION			

PROPRIETARY AND CONFIDENTIAL
 THE INFORMATION CONTAINED IN THIS DRAWING IS THE SOLE PROPERTY OF
 CRIBBIT COMPANY AND SHALL NOT
 BE REPRODUCED OR TRANSMITTED IN ANY FORM OR BY ANY MEANS, ELECTRONIC OR MECHANICAL, WITHOUT THE WRITTEN PERMISSION OF
 CRIBBIT COMPANY AND HEREIN IS
 PROHIBITED.

SIZE	DWG. NO.	REV
D		
WEIGHT:		SHEET 1 OF 1

ITEM NO.	PART NUMBER	DESCRIPTION	QTY.
1	600-00016-01	Speedo Plexi	1
2	500-00006-01	SPEEDO BOARD	1
3	603-00007-01-PART	FAIRING	1
4	#10 WASHER	BLACK HARDWARE	8
5	F&F HOOP CAP 2	CAP WITH CHECKERED FLAGS LOGO	1
6	8-32nylock	ZINC HARDWARE	4
7	702-00010-00	START-LG DVALCORN HAP#59-801-83301874	1
8	702-00011-00	TUNES - SM DVL DRG HAP#59-600-82262132	1
9	702-00009-00	VIEW - SM DVL BLUE HAP#59-600-82262133	1
10	#8-32 TORX-125	BLACK HARDWARE	4

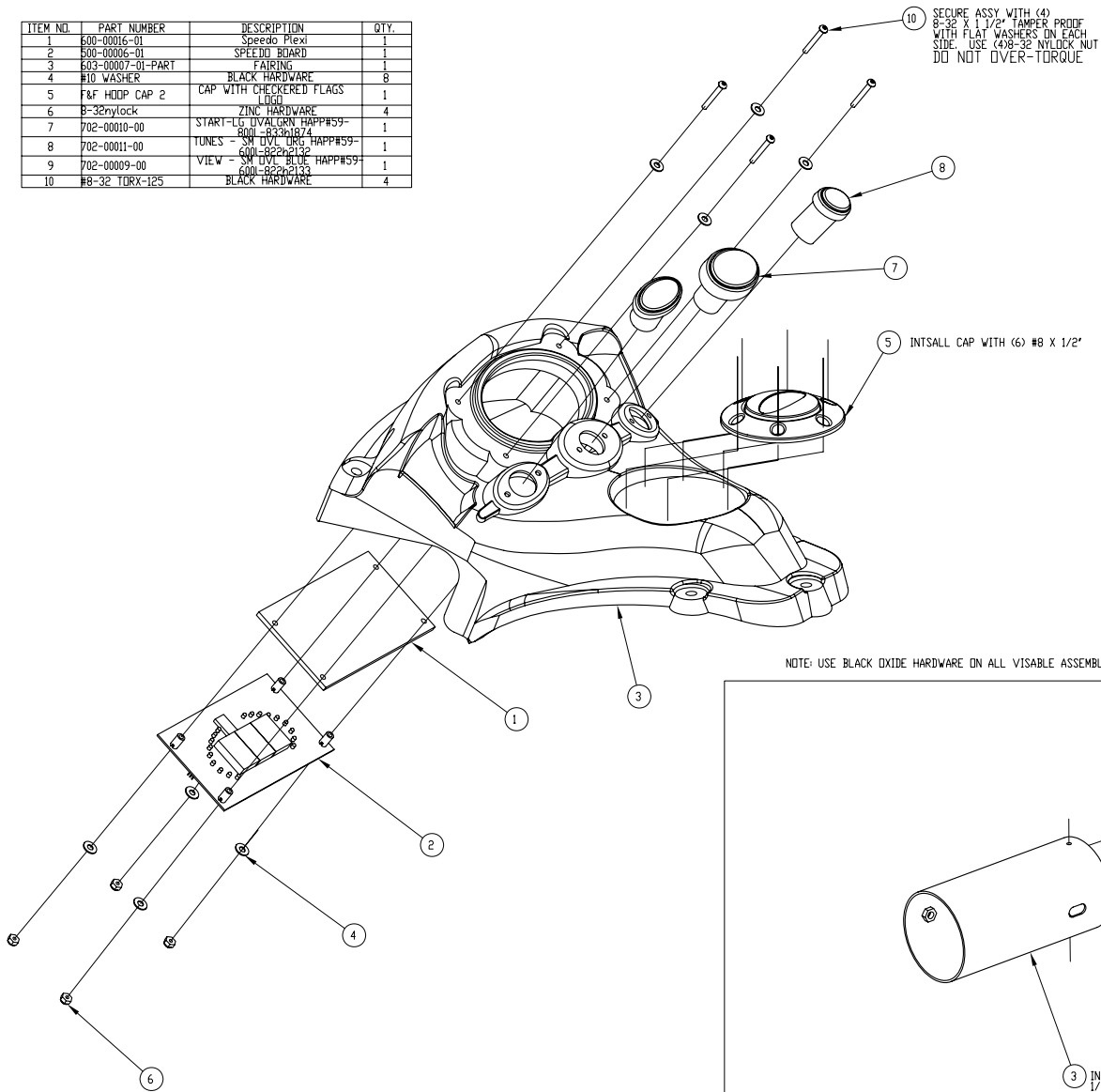

ITEM NO.	PART NUMBER	DESCRIPTION	QTY.
1	602-00006-00	TAIL LIGHT BRACKET	1
2	600-00005-01	BRAKE LED BOARD	1
3	#6-32 standoff-25	INSTALLED BY METAL FAB VENDOR	2
4	603-00006-01	BRACKET LIGHT COVER	1
5	#6-32 PHIL-50	#6-32x1/2in philips hd screw	2

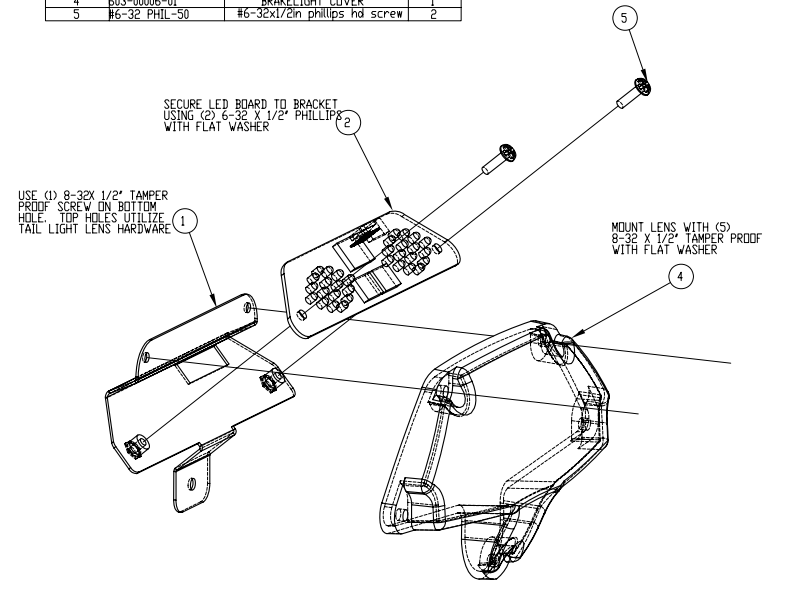

ITEM NO.	PART NUMBER	DESCRIPTION	QTY.
1	603-00005-01	TAILPIPE CAP	1
2	500-00004-01	Tailpipe LED Board	1
3	608-00015-01	TAILPIPE	1

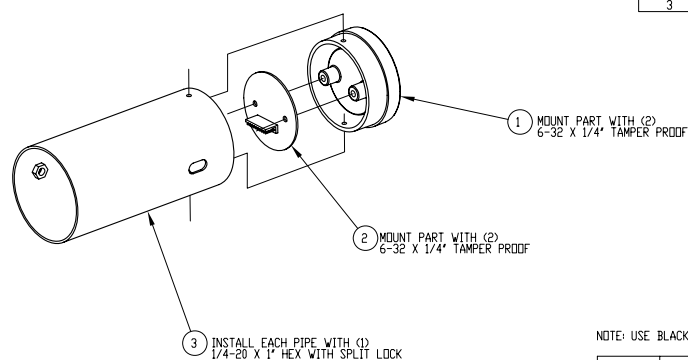

UNLESS OTHERWISE SPECIFIED		NAME	DATE	TITLE
DIMENSIONS ARE IN INCHES	DRAWN			SUB-ASSEMBLY
TOLERANCES	CHECKED			
PROTECTIVE COATING	ENG. APPR.			
MATERIAL	INSPECTION			SIZE DWG. NO. REV
FINISH	REWORK			WEIGHT: SHEET 1 OF 1

PROPERTY AND CONFIDENTIALITY NOTICE: THE INFORMATION CONTAINED IN THIS DRAWING IS THE SOLE PROPERTY OF... ANY REPRODUCTION OR DISSEMINATION OF THIS DRAWING WITHOUT THE WRITTEN PERMISSION OF... IS PROHIBITED.

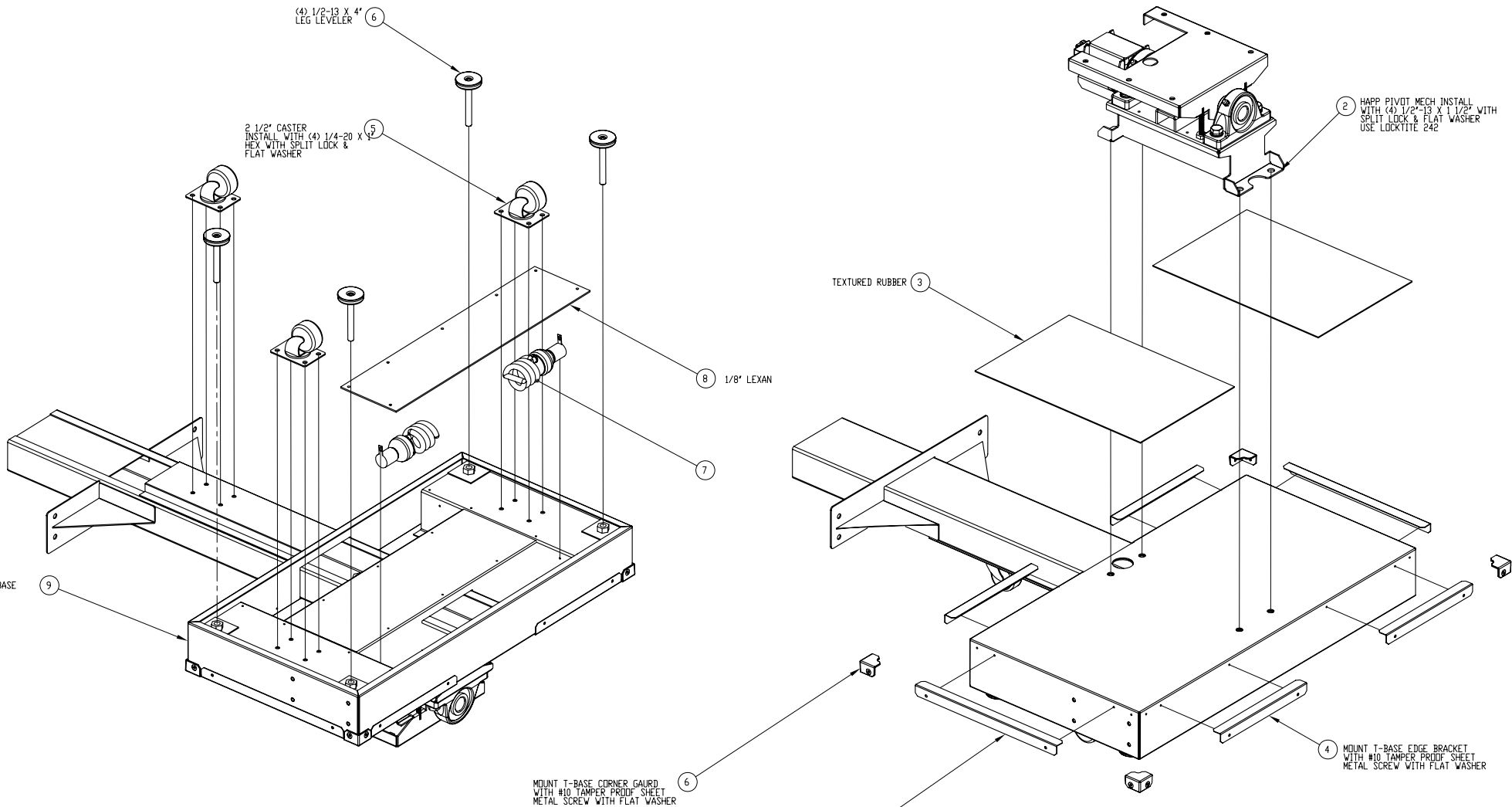

ITEM NO.	PART NUMBER	DESCRIPTION	QTY.
1	606-00027-01	FFSB-Floor Mat	2
2	602-00016-01	Y-Base Loge Bracket	4
3	602-00017-00	T-Base Edge Bracket Long	2
4	603-00019-01	T-base Corner Guard	4
5	Caster 2'S	SUPPLIED BY CONTRACT ASSEMBLER	3
6	#1LEG LEVELER	SUPPLIED BY CONTRACT ASSEMBLER	4
7	B20-00005-00	Pedestal Seat Lamp	2
8	600-00020-01	Bike T-Base Plexi	1
9	604-00006-01	T-BASE WELDED ASSY	1
10	604-00003-01	PIVOT ASSEMBLY - SUPERBIKES HAPP#50-2664-10	1

NOTE: EDGE BRACKETS AND CORNER GAURDS USE BLACK OXIDE HARDWARE

UNLESS OTHERWISE SPECIFIED		NAME	DATE	RAW THRILLS, INC.
DIMENSIONS ARE IN INCHES	DRAWN	JJ	4.16.06	
TOLERANCES	DESIGNED			STEELBASEHAPP
FRITTING	MANUFACTURED BY			RETROEXPLODE
FINISH	INSPECTION			SIZE DWG. NO.
TOO PLACE DIMENSION	DATE			D
DATE PLACE ORDER	REV			SCALE: 1/4" = 1"
DATE PLACE ORDER	REV			WEIGHT:
DATE PLACE ORDER	REV			SHEET 1 OF 1

PROPERTY AND CONFIDENTIALITY OF THE BUREAU OF INVESTIGATION IS HEREBY DECLARED. THIS DRAWING IS THE PROPERTY OF RAW THRILLS, INC. IT IS TO BE USED FOR THE PURPOSES OF THIS PROJECT ONLY. IT IS NOT TO BE REPRODUCED OR TRANSMITTED IN ANY FORM OR BY ANY MEANS, ELECTRONIC OR MECHANICAL, INCLUDING PHOTOCOPYING, RECORDING, OR BY ANY INFORMATION STORAGE AND RETRIEVAL SYSTEM.



Additional Notes and Contact Information:

Game: The Fast and the Furious Super Bikes

Model:

Serial Number:

Copyright and License Notice:

“The Fast and the Furious Super Bikes” is a trademark and copyright of Universal Studios licensed by Universal Studios Licensing L.L.L.P. All rights reserved.

Parental Advisory

A note to parents: The Fast and the Furious Super Bikes is rated PG-13. Consult www.filmratings.com for further information.

Aprilia: RSV 1000™, SXV™ designs, marks and emblems are registered trademarks of © Piaggio Group Americas, Inc. 2006. Aprilia® is a U.S. and worldwide registered trademark of the Piaggio Group of companies. Obey local traffic safety laws and always wear a helmet, appropriate eyewear and proper apparel. Used under license to Raw Thrills, Inc.

Ducati: Monster S4R™, Paul Smart 1000 Limited Edition™ and Supersport 1000™ designs, marks and emblems are trademarks of Ducati Motor Holding S.p.A. and are used under license to Raw Thrills, Inc.

Kawasaki: KX-250™, Ninja ZX-10R™, Vulcan 800 Drifter™ designs, marks and emblems are trademarks of Kawasaki Motors Corporation, USA and are used under license to Raw Thrills, Inc. KAWASAKI, [PARTICULAR TRADEMARK(S) USED] ARE TRADEMARKS LICENSED BY KAWASAKI MOTORS CORP., U.S.A., WHICH DOES NOT MANUFACTURE OR DISTRIBUTE THIS PRODUCT. CONSUMER INQUIRIES SHOULD BE DIRECTED TO: Betson, Inc.

Moto Guzzi: Grisso™, MGS-01 Corsa™ designs, marks and emblems are trademarks of © Piaggio Group Americas, Inc. 2006. Moto Guzzi® is a U.S. and worldwide registered trademark of the Piaggio Group of companies. Obey local traffic safety laws and always wear a helmet, appropriate eyewear and proper apparel. Used under license to Raw Thrills, Inc.

Yamaha: Yamaha, the Tuning Fork Mark, R1 and likeness thereof including the color Yamaha Blue, Road Star Warrior and the likeness thereof, Star Logo, R6 and the likeness thereof including the color Yamaha Blue, VMAX and the likeness thereof are trademarks of Yamaha Motor used under license. Used under license to Raw Thrills, Inc.

The motorcycle racing and riding experience in this video game is intended to be fanciful; do not try these moves in real life. Be a responsible rider. Riding a real motorcycle is an exercise in responsibility to yourself, to others and to the environment. A real motorcycle is not a toy and can be hazardous to operate. When riding a real motorcycle, wear an approved helmet and proper riding gear. Observe all state and local laws. Respect the rights of others. Ride within your capabilities, allowing extra time for maneuvering and braking. Never drink and ride. Read and follow all instructional materials that you receive with your motorcycle.